

KENWOOD

KGC-9044

11 BAND GRAPHIC EQUALIZER

INSTRUCTION MANUAL

11 EGALISEURS GRAPHIQUES DE BANDE

MODE D'EMPLOI

11 ECUALIZADOR GRÁFICO

MANUAL DE INSTRUCCIONES

KENWOOD CORPORATION

Take the time to read through this instruction manual.

Familiarity with installation and operation procedures will help you obtain the best performance from your new graphic equalizer.

For your records

Record the serial number, found on the back of the unit, in the spaces designated on the warranty card, and in the space provided below. Refer to the model and serial numbers whenever you call upon your KENWOOD dealer for information or service on the product.

Model KGC-9044 Serial number _____

© PRINTED IN JAPAN B64-1421-00 (K) (MC)

00/2 1 99/12 11 10 9 8 7 6 5 4 3 2 1

Contents

Before use	
Safety precautions	2
Buttons and Display	4
Equalizer operations	
KBS (Kenwood Built-in Sound)	4
Equalizer Adjustment	5
Equalizer Curve Memory	5
Other operations	
Menu System	6
Switching Spectrum Analyzer Display	7
Automatic Dimmer Munction	7
Input Sensitivity Adjustment	7
Theft Deterrent Faceplate	8
Installation	
Accessories	9
Installation Procedure	9
Connections	10
Installation	10
Troubleshooting guide	13
Specifications	14

Safety precautions

▲WARNING

To prevent injury and/or fire, take the following precautions:

- Insert the unit all the way until it is fully locked in place. Otherwise it may fly out of place during collisions and other jolts.
- When extending the battery or ground wires, make sure to use automotive-grade wires or other wires with an area of 0.75mm² (AWG18) or more to prevent wire deterioration and damage to the wire coating.
- To prevent short circuits, never put or leave any metallic objects (e.g., coins or metal tools) inside the unit.
- Make sure not to get your fingers caught between the faceplate and the unit.
- If the unit starts to emit smoke or strange smells, turn off the power immediately and consult your Kenwood dealer.
- Be careful not to drop the unit or subject it to strong shock.

The unit may break or crack because it contains glass parts.

FCC WARNING

This equipment may generate or use radio frequency energy. Changes or modifications to this equipment may cause harmful interference unless the modifications are expressly approved in the instruction manual. The user could lose the authority to operate this equipment if an unauthorized change or modification is made..

▲CAUTION

To prevent damage to the machine, take the following precautions:

- Make sure to ground the unit to a negative 12V DC power supply.
- Do not open the top or bottom covers of the unit.
- Do not install the unit in a spot exposed to direct sunlight or excessive heat or humidity. Also avoid places with too much dust or the possibility of water splashing.
- Do not set the removed faceplate or the faceplate case in areas exposed to direct sunlight, excessive heat or humidity. Also avoid places with too much dust or the possibility of water splashing.
- Do not subject the faceplate to excessive shock, as it is a piece of precision equipment.
- To prevent deterioration, do not touch the terminals of the unit or faceplate with your fingers.
- When replacing a fuse, only use a new one with the prescribed rating. Using a fuse with the wrong rating may cause your unit to malfunction.
- To prevent short circuits when replacing a fuse, first disconnect the wiring harness.
- Do not place any object between the faceplate and the unit.
- During installation, do not use any screws except for the ones provided. The use of improper screws might result in damage to the main unit.

NOTE

- If you experience problems during installation, consult your Kenwood dealer.
- If the unit does not seem to be working right, try pressing the reset button first. If that does not solve the problem, consult your Kenwood dealer.

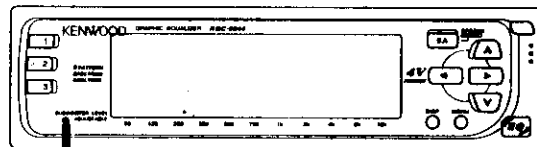

Reset button

Cleaning the Faceplate Terminals

If the terminals on the unit or faceplate get dirty, wipe them with a dry, soft cloth.

Cleaning the Unit

If the front panel gets dirty, turn off the power and wipe the panel with a dry silicon cloth or soft cloth.

▲CAUTION

Do not wipe the panel with a stiff cloth or a cloth dampened by volatile solvents such as paint thinner and alcohol. They can scratch the surface of the panel and/or cause the indicator letters to peel off.

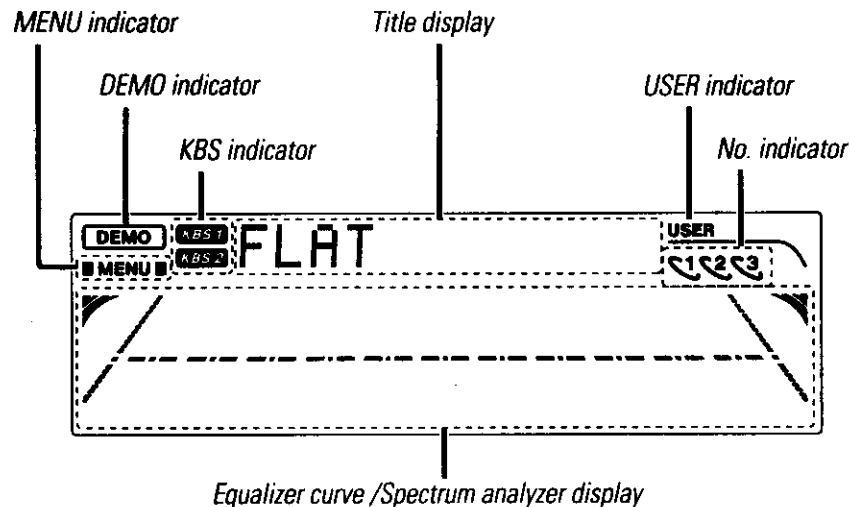
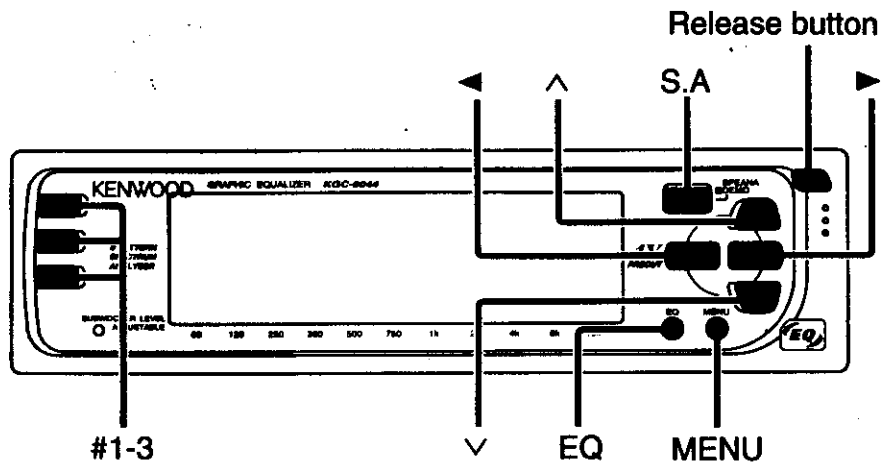

Equalizer operations

KBS (Kenwood Built-in Sound)

Four types of loudness levels and equalizer curves for rock, pops, vocal, and flat music genre have been preset. You can call up an equalizer curve for each genre at the touch of a button.

Switching between KBS1, KBS2 and USER:

- 1 Press the EQ button.
- 2 Each time you press the EQ button, the function changes from KBS1 to KBS2 to USER.



When KBS1 or KBS2 or USER is ON, the respective KBS1 or KBS2 or USER indicator lights. Initially, KBS1 is turned on.

Selecting an equalizer curve preset in KBS1 or KBS2 or USER:

Press any one of buttons 1 to 3. The selected curve is set and displayed, and the sound quality is changed accordingly.

No. indicator	KBS / USER indicator		
	KBS 1	KBS 2	USER
1	"ROCK"	"LOUD 1"	"PRESET 1"
2	"POPS"	"LOUD 2"	"PRESET 2"
3	"VOCAL"	"LOUD 3"	"PRESET 3"

NOTE

ROCK: For rock sounds, POPS: For pops sounds, VOCAL: For vocal sounds, LOUD1-3: Loudness curves, PRESET1-3: User preset curves,

Canceling equalizer effects:

Press the EQ button for more than one second to change the flat curves("FLAT").

Equalizer Adjustment

You can adjust the sound level to suit your preference among 11 frequencies: 60 Hz, 120 Hz, 250 Hz, 380 Hz, 500 Hz, 750 Hz, 1 kHz, 2 kHz, 4 kHz, 8 kHz, and 16 kHz.

Selecting Band for Adjustment:

Each time you press the ◀ button, the band shifts to the left (lower frequencies), while each time you press the ▶ button, the band shifts to the right (higher frequencies).

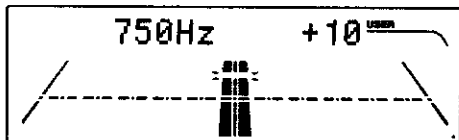

Increasing Level:

Press the ^ button while the band indicator is blinking.
The level indicator goes up.
The level can be adjusted up to +12 (by two steps).

Decreasing Level:

Press the v button while the band indicator is blinking.
The level indicator goes down.
The level can be adjusted down to -12 (by two steps).

NOTE

- When adjusting the equalizer level, do not adjust solely a single band. Adjust each band to form a curve.
- Equalizer adjustment mode will be cancelled automatically if no buttons are pressed for five seconds.

Equalizer Curve Memory

You can store four types of adjusted equalizer curves in memory, and can call up an original equalizer curve at the touch of a button.

- 1 To adjust the sound quality to your preference.
- 2 Hold down any one of buttons 1 to 3 for more than 2 seconds. The adjusted equalizer curve will be stored in memory.

NOTE

Up to 3 equalizer curves can be stored in memory.

Recalling Equalizer Curve from Memory:

- 1 Press the EQ button, select "USER MODE".
- 2 Press any one of buttons 1 to 3. The equalizer curve stored by the respective button number (1 to 3) will be recalled. The number (1 to 3) of the pressed button is displayed.

Menu System

To accommodate a greater number of functions, a function set system has been employed for making settings. Press the MENU button to enter the function set mode and then display the function to make the setting.

- 1 Press the MENU button to enter the function set mode, and the MENU indicator lights.
- 2 Press the ◀ or ▶ button. Each time the button is pressed, the adjustment mode will change as follows:

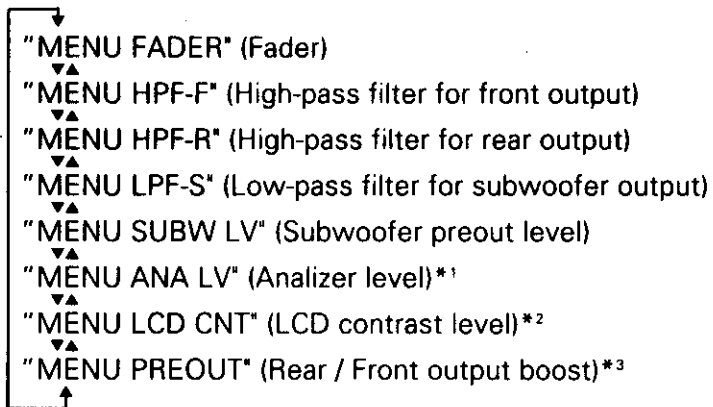

- 3 Press the ^ or v button. Look at the table to adjust the mode being displayed.
 - 4 Press the MENU button to end the function set mode.
- *1: It varies according to the volume setting on the centre unit, so set the volume level to normal on the centre unit before adjusting it.
 *2: The contrast on the equaliser/spectrum analyser display is not adjustable.
 *3: If the sensitivity of the connected amp is high enough to accommodate 4V, set the boost level to "HIGH". Otherwise, set it to "LOW". If it has been set to "HIGH", set the input sensitivity on the amp side to 4V. If it is set lower than 4V, noise may be output.

NOTE

The menu settings cannot be stored in the user memory.

Table of Adjustment Mode

Adjustment mode (Display)	Operation of Control button	
	^ button	v button
Fader ("FADER")	Front channel emphasized.(F15)	Rear channel emphasized.(R15)
High-pass filter for front output ("HPF-F")	You can select the frequency to be cut, as follows: OFF (through) ↔ 40Hz ↔ 60Hz ↔ 80Hz ↔ 100Hz ↔ 120Hz ↔ 150Hz ↔ 180Hz ↔ 220Hz	
High-pass filter for rear output ("HPF-R")	You can select the frequency to be cut, as follows: OFF (through) ↔ 40Hz ↔ 60Hz ↔ 80Hz ↔ 100Hz ↔ 120Hz ↔ 150Hz ↔ 180Hz ↔ 220Hz	
Low-pass filter for subwoofer output ("LPF-S")	You can select the frequency to be cut, as follows: 50Hz ↔ 80Hz ↔ 120Hz ↔ OFF (through)	
Subwoofer Preout Level ("SUBW-LV")	The subwoofer sound is increased.	The subwoofer sound is decreased.
Analyzer level*1 ("ANA LV")	The spectrum analyzer level increased.	The spectrum analyzer level decreased.
LCD contrast level*2 ("LCD CNT")	The setting values higher.	The setting values lower.
Rear / Front output boost*3 ("PREOUT")	Boost on.("HIGH") ◀ ▶ Boost off.("LOW")	

Spectrum Analyzer Display Selection

You can select the display to enjoy sounds with eyes.

Switching the Spectrum Analyzer Display:

Each time you press the S.A button, the spectrum analyzer display switches as follows;

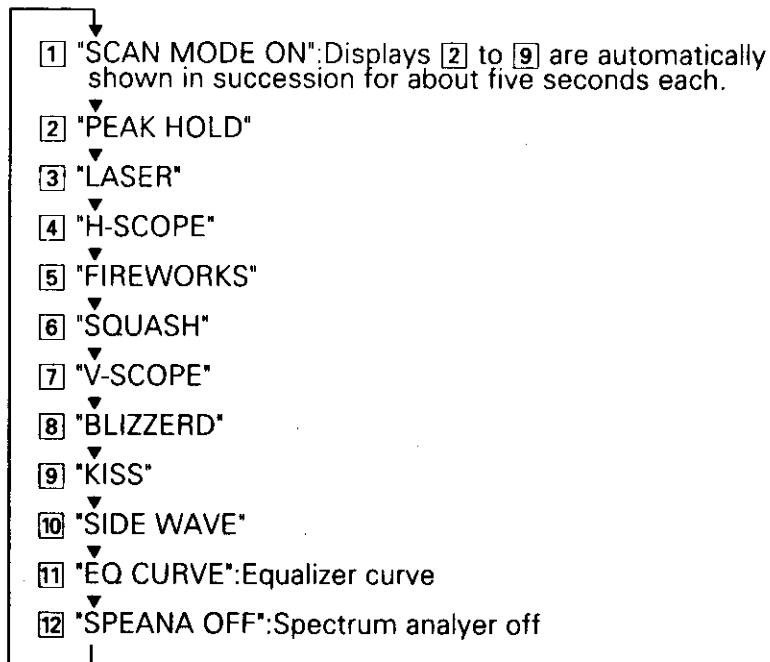

Automatic Dimmer Function

The display dims when the car's lights are turned on.

NOTE

The dimmer function is not available for units if the dimmer wire is not connected.

Demonstration Function

You can give a demonstration of the spectrum analyzer and the equalizer curves to know what displays this unit has. The DEMO indicator lights up when the demonstration function is on.

Starting Demonstration:

Pressing the S.A button for more than one second will turn on demonstration mode.

Cancelling Demonstration:

Press the S.A button.

Input Sensitivity Adjustment

Adjust this control according to the pre-out level of the centre unit connected to this unit.

- 1 Removing the faceplate (see page 8)
- 2 Adjusting the input sensitivity volume.

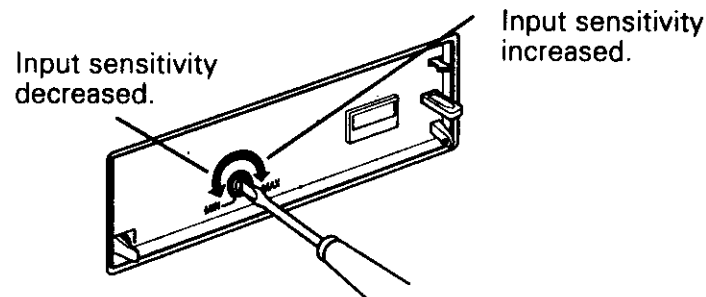

- 3 Reattaching the faceplate (see page 8)

NOTE

Refer to "Specifications" on the centre unit's instruction manual about the pre-out level. If the input sensitivity is not adjusted correctly, sound distortion may occur.

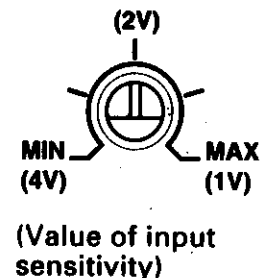

Other operations

English

Theft Deterrent Faceplate

The faceplate of the unit can be detached and taken with you, helping to deter theft.

Removing Faceplate:

Press the release button and drop open the faceplate. In its dropped condition, whilst drawing the faceplate to one side, pull it to the front and remove it.

Release button

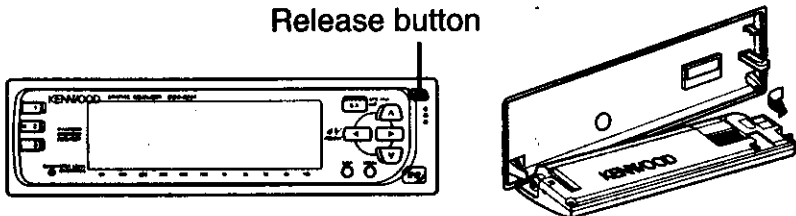

NOTE

- If the controls remain untouched for a period of 5 minutes or more after the panel has dropped open or been removed, the sound output stops automatically. (A warning beep starts sounding 30 seconds before the sound output stops automatically.)
- The faceplate is a precision piece of equipment and can be damaged by shocks or jolts. For that reason, keep the faceplate in its special storage case whilst detached.
- Do not expose the faceplate or its storage case to direct sunlight or excessive heat or humidity. Also avoid places with too much dust or the possibility of water splashing.

Reattaching Faceplate:

Hold the faceplate so that the operation face faces the front toward you and press until it locks. The faceplate will be set and the unit will be operational.

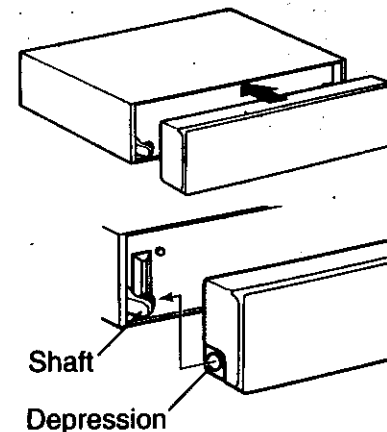

NOTE

When there is difficulty in setting the faceplate, align the depression on the left side of the faceplate with the shaft of the unit, then lock.

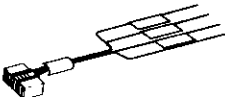

Accessories

External view

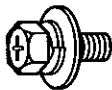
 Number of items
① 1
② 1
③ 2
④ 1

▲CAUTION

The use of any accessories except for those provided might result in damage to the unit. Make sure only to use the accessories shipped with the unit, as shown above.

External view

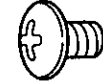
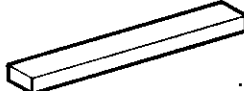
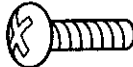
 Number of items
⑤ 4
⑥ 4
⑦ 2
⑧ 2

Installation Procedure

1. To prevent a short circuit, remove the key from the ignition and disconnect the \ominus battery.
2. Make the proper input and output cable connections for each unit.
3. Connect the wiring harness wires in the following order: ground, battery.
4. Connect the wiring harness connector to the unit.
5. Install the unit in your car.
6. Reconnect the \ominus battery.
7. Press the reset button.

▲CAUTION

- If the fuse blows, first make sure that the wires have not caused a short circuit, then replace the old fuse with one with the same rating.
- Do not let unconnected wires or terminals touch metal on the car or anything else conducting electricity. To prevent short circuits, also do not remove the caps on the ends of the unconnected wires or the terminals.
- After the unit is installed, check whether the brake lamps, indicators, wipers, etc. on the car are working properly.
- Insulate unconnected wires with vinyl tape or other similar material.
- Some disc changers need conversion wires for connection. See the section on "Safety Precautions" for details.
- If the console has a lid, make sure to install the unit so that the faceplate does not hit the lid when closing and opening.

Connections

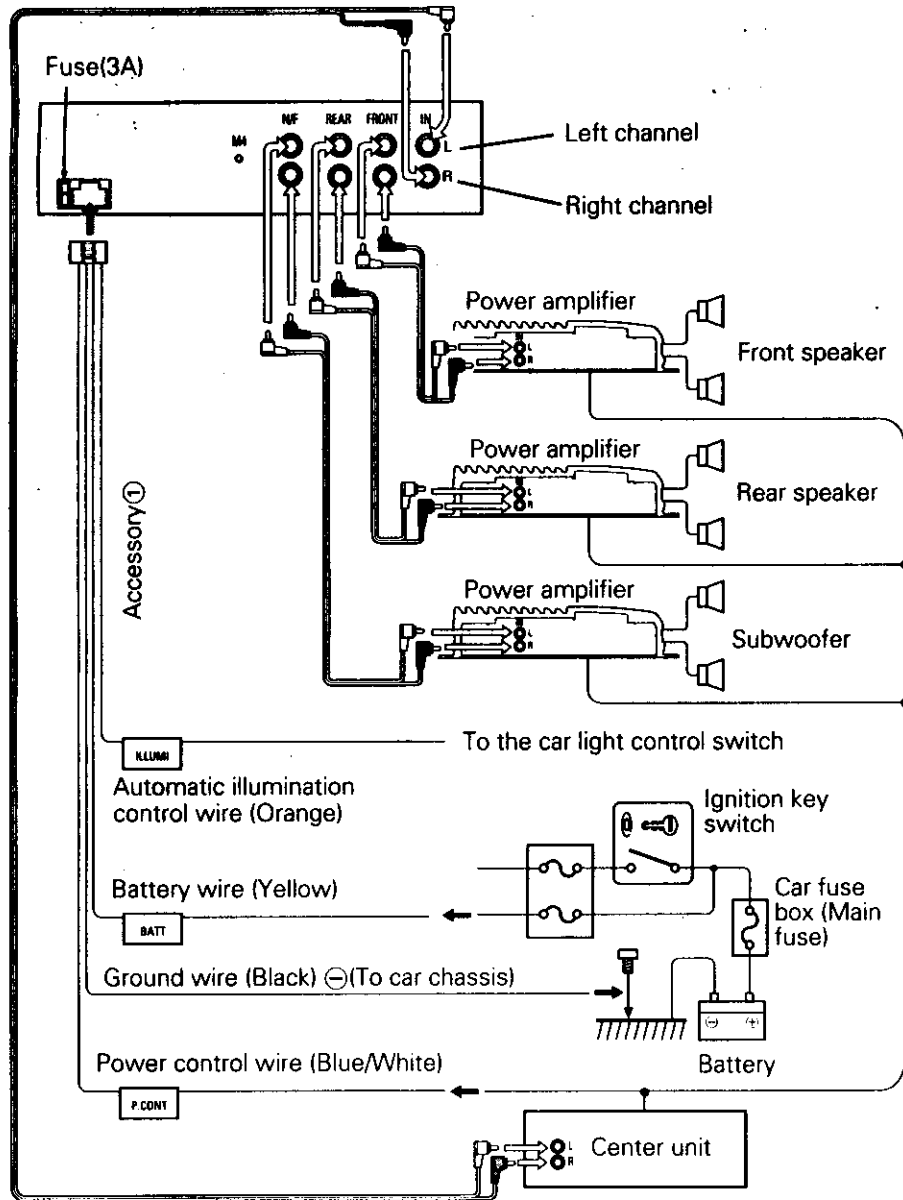

Installation

Installation

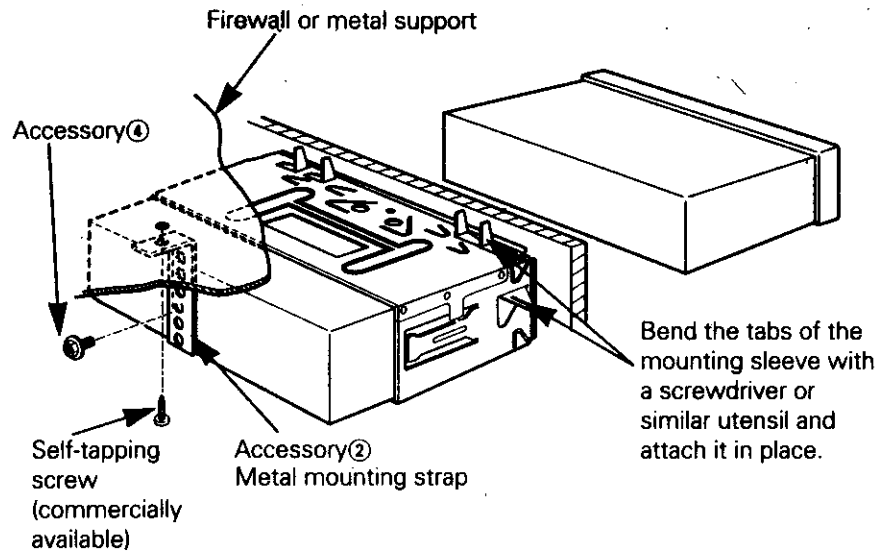

On cars where there is no compartment in the centre for installing a car audio unit:
Use the spacer ⑦ to affix the centre unit sleeve and the sleeve attached to the main unit in such a way that they are correctly aligned both depthwise and horizontally.

On cars lacking a centre compartment

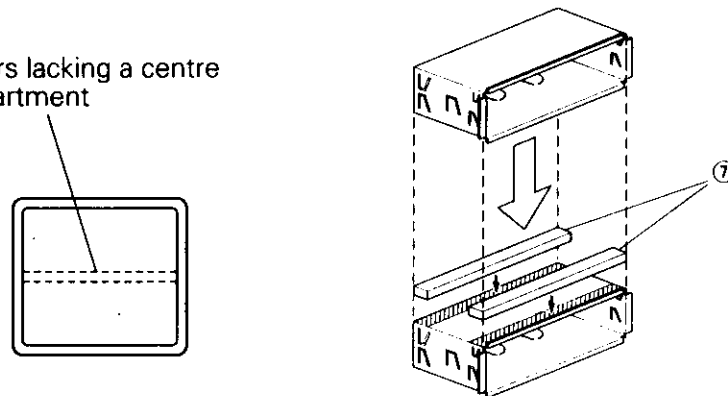

To the P.CONT terminal of the power amplifier

■ Installing in Japanese-Made Cars

- 1 Refer to the section "Removing the hard rubber frame (P.12)" and then remove the hard rubber frame.
- 2 Align the holes in the unit (two locations on each side) with the vehicle mounting bracket and secure the unit with the accessory screws.

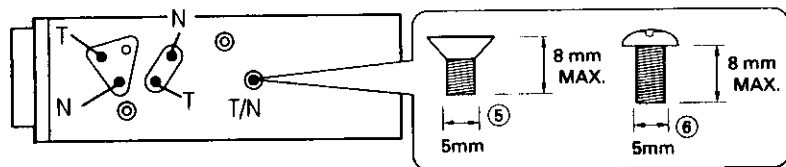

T: Toyota cars
N: Nissan cars

Accessory 5...for Nissan car
Accessory 6 ...for Toyota car

▲CAUTION

- During installation, do not use any screws except for those provided. The use of different screws might result in damage to the main unit.
- Damage may occur if a screwdriver or similar tool is used with excessive force during the installations.

■ Screwing the Faceplate on the Unit

If you want to fasten the faceplate to the main unit so that it does not fall off, insert the provided screw ($\varnothing 2.6 \times 12$ mm) in the holes as follows.

- 1 Insert one of the provided screws into hole ① so that the screw ① is perpendicular to the bottom panel of the unit.
- 2 Similarly, insert another provided screw into hole ②.

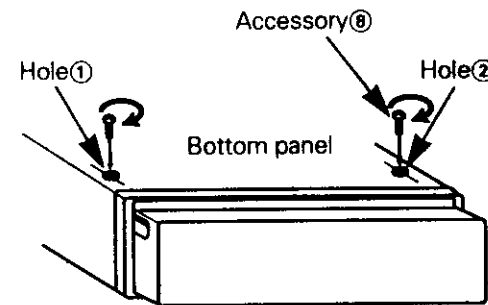

Ensure that the faceplate is fixed firmly before operating this unit.

▲CAUTION

Never insert the taptite screws ($\varnothing 2.6 \times 12$ mm) in any other screw holes than the one specified. If you insert it in another hole, it will contact and may cause damage to the mechanical parts inside the unit.

■ **Removing the hard rubber frame**

- 1 Engage the catch pins on the removal tool and remove the two locks on the lower level.
Lower the frame and pull it forward as shown in the figure.

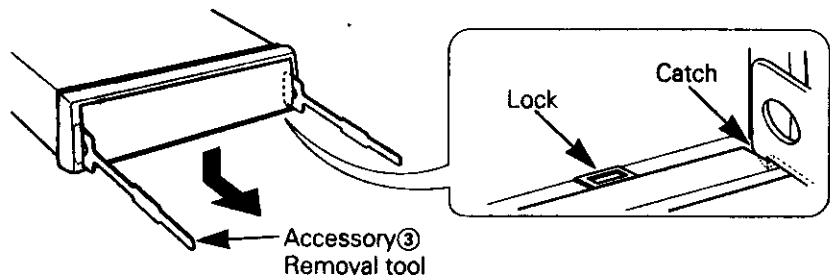

- 2 When the lower level is removed, remove the upper two locations.

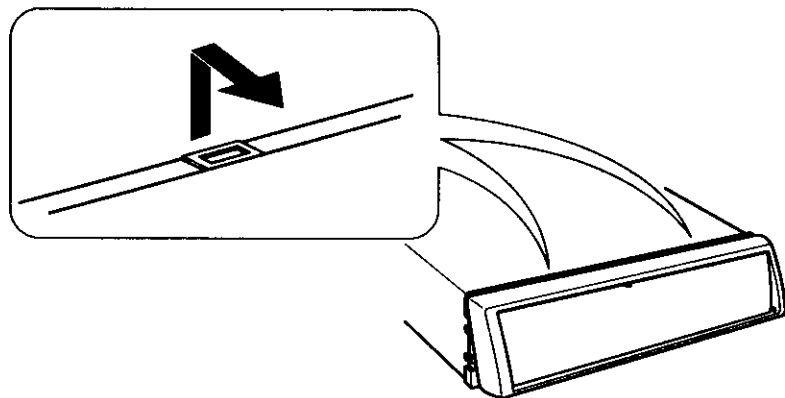

NOTE

The frame can be removed from the top side in the same manner.

■ **Removing the Unit**

- 1 Refer to the section "Removing the hard rubber frame" and then remove the hard rubber frame.
- 2 Remove the Hex-head screw with integral washer (M4x8) on the back panel.
- 3 Insert the two removal tools deeply into the slots on each side, as shown.

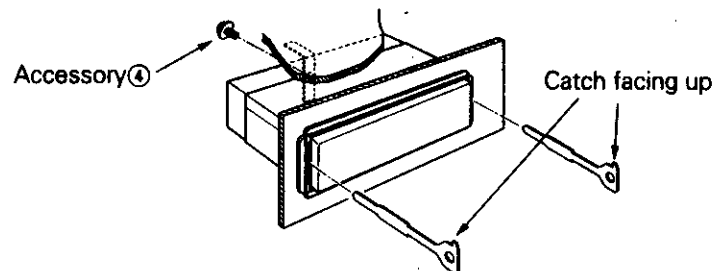

- 4 Lower the removal tool toward the bottom, and pull out the unit halfway whilst pressing towards the inside.

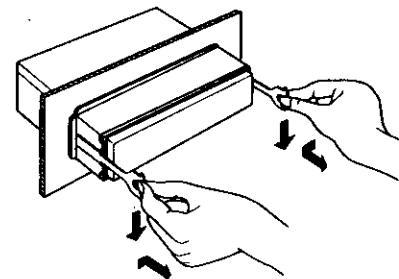

CAUTION

Be careful to avoid injury from the catch pins on the removal tool.

- 5 Pull the unit all the way out with your hands, being careful not to drop it.

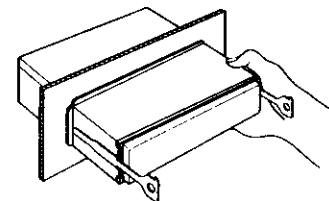

What might appear to be a malfunction in your unit may just be the result of slight misoperation or miswiring. Before calling service, first check the following table for possible problems.

PROBLEM	POSSIBLE CAUSE	SOLUTION
The power is not turned on.	The fuse has blown.	After checking for short circuits in the cables, replace the fuse with one having the same rating.
	The power control cable are connected incorrectly.	Connect the same cable to the centre unit.
No sound can be heard, or the volume is low.	The fader and/or balance settings are set all the way to one side.	Reset the fader and/or balance settings.
	The input/output cables or wiring harness are connected incorrectly.	Connect the input/output cable or wiring harness correctly. See "Connections".
	The main unit panel is open.	Close the panel.
The front or rear speaker does not output sound.	The fader is set to one side.	Adjust the fader.
Nothing happens when the buttons are pressed.	The computer chip in the unit is not functioning normally.	Press the reset button on the unit (see page 3).
The 16kHz indicator of the spectrum analyzer does not light.	In particular, the indicator may not light for a cassette tape because the 16kHz level of the source is low.	If it lights when you play a compact disc, there is no problem.
Hiss noise is generated.	The graphic equalizer level is too high.	Set the graphic equalizer level to a correct level.
	The power amp input sensitivity setting is wrong.	If the front and rear level gain is set to "HIGH", set the power amp input sensitivity to 4V.
The sound is distorted.	The main unit input sensitivity setting is wrong.	Match the main unit input sensitivity setting to the output voltage of the centre unit (see page 7).

Specifications

Specifications subject to change without notice.

Equalizer section

Equalizer centre frequencies	60 Hz, 120 Hz, 250 Hz, 380 Hz, 500 Hz, 750 Hz, 1 kHz, 2 kHz, 4 kHz, 8 kHz, 16 kHz
Equalizer range	-10 ~ +10 dB
Subwoofer Cut-off Frequency	50Hz, 80Hz, 120Hz
Subwoofer Output Gain	-80 ~ +10 dB
Subwoofer Cut-off Slope	12 dB / oct.
Hi-pass Filter Cut-off Frequency	40 Hz, 60 Hz, 80 Hz, 100 Hz, 120 Hz, 150 Hz, 180 Hz, 220 Hz
Hi-pass Filter Cut-off Slope	12 dB / oct.

Audio section

Input Impedance	10 k Ω
Sensitivity(MAX)	1 V
Sensitivity(MIN)	4 V
Output Level/Load	4 V / 600 Ω
Signal to Noise Ratio (2V input, VR:Centre, EQ:Flat)	88 dB
T.H.D	0.01 %
Frequency Responce (0 ~ -3dB)	10 Hz ~ 40 kHz
Gain (2V input, VR:Centre, EQ:Flat, Gain:Off)	-13.4 dB ~ -25.2 dB

General

Operating voltage	14.4 V (11 – 16 V allowable)
Current consumption	0.3 A
Installation size (W x H x D)	182 x 50 x 145 mm 7-3/16 x 1-15/16 x 5-3/4 in
Weight	0.9 kg (2.0 Lbs)